

PIVOT™ v3

PASSENGER & DRIVER SIDE
ASSEMBLY | USER GUIDE



ASSEMBLY VIDEO

Table of Contents

1	Introduction	3
	Safety Instructions	3
	RV Compatibility Warning	5
	Hitch Capacity	6
	Parts, Tools, Important Notes & Tips	8
2	Installation	9
	Hitch Installation	9
	Rack/Cargo Installation	11
3	PIVOT™ v3 Use Guide	12
	Swing Operation	12
4	PIVOT™ v3 FAQs	17
5	No Worries Limited Warranty	18

Dangers, Warnings, Cautions and Notices

Particularly important information is presented in the following form:

 CAUTION
This danger symbol identifies special instructions or procedures which, if not correctly followed, will result in serious injury, or death.

 WARNING
This warning symbol identifies special instructions or procedures which, if not correctly followed, could result in serious injury, or death.

 CAUTION
This caution symbol identifies special instructions or procedures which, if not strictly observed, could result in minor or moderate injury.

NOTICE
This symbol indicates points of particular interest for more efficient and convenient operation.

SAFETY INSTRUCTIONS

Failure to follow these safety instructions voids the product warranty and holds you responsible for any damage or accidents.

PIVOT™ v3

Max Weight	Weight Per Length	RV Compatibility	Hitch Requirement
250lb	250 lb < 28"	Not Compatible	Minimum Class III
113kg	150 lb < 40"		
See Weight Compatibility on page 6-7			

WARNING

- Do not tow with this product.
- Confirm the product you intend to use in the Pivot v3 is approved by the manufacturer.
- You are responsible for confirming you do not exceed your vehicle's tongue hitch weight.
- Do not use this product upside down.
- Not compatible with vertical bike racks.
- The Pivot v3 is intended for use with 2" hitch receivers only. No other adapters or reducers are approved. Use of third-party or non-approved components may result in improper fit, instability, or damage. 3" hitch receivers are not supported.
- Must mount to your vehicle's receiver directly. Do not use hitch extenders.
- Do not use tarps, rain covers or wind covers with this product.
- Drive responsibly. Additional weight and distance may affect vehicle handling. Be extra cautious when entering driveways or incline approaches to ensure proper clearance.
- Read the [Limited Warranty](#) for additional guidelines and limitations.
- Ensure safety pin, lever, and toggle clamp are secure before each use.
- Check the tightness of all bolts and hardware before each use.
- Regularly check your rack for damaged, worn, and/or missing parts. Replace parts on your rack only with Kuat-branded parts obtained from Kuat or a Kuat dealer. Do not otherwise modify the Pivot v3.
- Always secure and lock the hitch pin each time you use the Pivot v3.
- Always check with and abide by state and local laws while using this product.

NOTICE

- Do not take through automatic car wash.
- The locking hitch pin does not guarantee theft prevention, but when used properly, it can help deter a potential threat.
- Remove the Pivot v3 from your vehicle when not in use and store it in a clean, dry place.

SAFETY INSTRUCTIONS CONT.

El incumplimiento de estas instrucciones de seguridad anula la garantía del producto y le hace responsable de cualquier daño o accidente.

Le non-respect de ces consignes de sécurité entraîne l'annulation de la garantie du produit et vous rend responsable de tout dommage ou accident.

PIVOT™ v3

Peso Máximo / Poids Maximal	Peso Por Longitud / Poids Par Longueur	Compatibilidad con vehículos recreativos / Compatibilité avec les véhicules récréatifs	Requisitos del enganche / Exigences relatives à l'attelage
250lb	250 lb < 28"	No Compatible	Mínimo Clase III
113kg	150 lb < 40"		
	Consulte Peso Compatibilidad en la página 6-7	Non Compatible	Minimum Clase III
	Voir Poids Compatibilité à la page 6-7		

⚠ ADVERTENCIA

- No remolque con este producto.
- Confirme que el producto que desea utilizar en el Pivot v3 esté aprobado por el fabricante.
- Usted es responsable de confirmar que no excede el peso máximo permitido para el enganche de su vehículo.
- No utilice este producto boca abajo.
- No es compatible con portabicicletas verticales.
- El Pivot v3 está diseñado exclusivamente para utilizarse con enganches de 2 pulgadas. No se admite el uso de ningún otro adaptador o reductor. El uso de componentes de terceros o no homologados puede provocar un ajuste incorrecto, inestabilidad o daños. No es compatible con enganches de 3 pulgadas.
- Debe montarse directamente en el receptor de su vehículo. No utilice extensores de enganche.
- No utilice lonas, cubiertas para la lluvia o cubiertas para el viento con este producto.
- Conduzca de forma responsable. Conduzca con responsabilidad. El peso adicional y la distancia pueden afectar al manejo del vehículo. Extreme la precaución al entrar en caminos de acceso o pendientes para garantizar una distancia libre adecuada.
- Lea la garantía limitada para conocer las directrices y limitaciones adicionales.
- Asegúrese de que el pasador de seguridad, la palanca y la abrazadera de palanca estén bien sujetos antes de cada uso.
- Compruebe el apriete de todos los pernos y herrajes antes de cada uso.
- Compruebe regularmente si su portabicicletas tiene piezas dañadas, desgastadas o faltantes. Reemplace las piezas de su portabicicletas solo por piezas de la marca Kuat obtenidas de Kuat o de un distribuidor de Kuat. No modifique el Pivot v3 de ninguna otra manera.
- Asegure y bloquee siempre el pasador del enganche cada vez que utilice el Pivot v3.
- Consulte siempre las leyes estatales y locales y cúmplalas mientras utiliza este producto.

AVISO

- No lo lleve a lavaderos automáticos.
- El pasador de bloqueo del enganche no garantiza la prevención de robos, pero cuando se utiliza correctamente, puede ayudar a disuadir una posible amenaza.
- Retire el Pivot v3 de su vehículo cuando no lo utilice y guárdelo en un lugar limpio y seco.

⚠ AVERTISSEMENT

- Ne tractez pas avec ce produit.
- Vérifiez que le produit que vous comptez utiliser avec le Pivot v3 est approuvé par le fabricant.
- Il vous incombe de vérifier que vous ne dépassez pas le poids maximal autorisé pour l'attelage de votre véhicule.
- N'utilisez pas ce produit à l'envers.
- Non compatible avec les porte-vélos verticaux.
- Le Pivot v3 est exclusivement destiné à être utilisé avec des attelages de 2 pouces. Aucun autre adaptateur ou réducteur n'est homologué. L'utilisation de composants tiers ou non homologués peut entraîner un mauvais ajustement, une instabilité ou des dommages. Les attelages de 3 pouces ne sont pas pris en charge.
- Il doit être monté directement sur le récepteur de votre véhicule. N'utilisez pas de rallonges d'attelage.
- N'utilisez pas de bâches, de housses de pluie ou de housses anti-vent avec ce produit.
- Conduisez de manière responsable. Le poids supplémentaire et la distance peuvent affecter la maniabilité du véhicule. Soyez particulièrement prudent lorsque vous empruntez des allées ou des pentes afin de vous assurer que la garde au sol est suffisante.
- Veuillez consulter la garantie limitée pour connaître les conditions et restrictions supplémentaires.
- Assurez-vous que la goupille de sécurité, le levier et la pince à bascule sont bien fixés avant chaque utilisation.
- Vérifiez le serrage de tous les boulons et pièces avant chaque utilisation.
- Vérifiez régulièrement votre porte-vélos pour détecter toute pièce endommagée, usée et/ou manquante. Remplacez les pièces de votre porte-vélos uniquement par des pièces de marque Kuat obtenues auprès de Kuat ou d'un revendeur Kuat. Ne modifiez pas le Pivot v3 de quelque manière que ce soit.
- Fixez et verrouillez toujours la goupille d'attelage chaque fois que vous utilisez le Pivot v3.
- Vérifiez toujours les lois nationales et locales et respectez-les lorsque vous utilisez ce produit.

AVIS

- Ne passez pas dans un lavage automatique.
- La goupille de verrouillage ne garantit pas la prévention du vol, mais lorsqu'elle est utilisée correctement, elle peut contribuer à dissuader une menace potentielle.
- Retirez le Pivot v3 de votre véhicule lorsque vous ne l'utilisez pas et rangez-le dans un endroit propre et sec.

Küat RV Compatibility Warning

Küat's limited warranty only covers the use of some of its receiver hitch-mounted bicycle racks with some recreational vehicles (RVs), as described below. Many types of RVs subject the rack and bicycles on it to high forces and extreme movements. Damage resulting from the use of a Küat product in violation of this section is not covered by this limited warranty.

Küat's limited warranty will cover use of any of its 2-inch receiver hitch-mounted bicycle racks on Class B type motorhomes, commonly known as van conversions (as defined in 49 C.F.R. 571.3), satisfying all of the following requirements:

The receiver hitch is directly attached to the motorhome chassis, not just to the bumper;
The rear-most point of the receiver hitch, where the bicycle rack will be attached, is no more than 64 inches from the rear axle of the motorhome; and
The vehicle is a class B type motorhome as described below.

Class B type motorhomes are commonly known as van conversions and comprise a completed van-type vehicle that has been altered to provide temporary living quarters. Class B type motorhomes have a gross vehicle weight rating of 10,000 lbs or less.

In addition, (i) the 2-inch receiver Transfer™ v2, (ii) the 2-inch receiver Piston ION, (iii) the 2-inch receiver Piston Pro X, (iv) the 2-inch receiver Piston Pro, and (v) the Piston SR with 2" Hitch Adapter may be used on RVs (both motorhomes and trailers) satisfying all of the following requirements:

The receiver hitch is directly attached to the RV chassis, not just to the bumper;
No hitch extender or swing-away rack attachment is being used; and
The bike rack is in its original configuration, with no add-on rack attachments.

Please check the product User Guide for load weight limits applicable to your rack when used on an RV. Lower weight limits apply.

Even if the conditions above are met, any RV may be operated in a way that will expose Küat's products to conditions that they are not designed to handle. The RV operator is responsible for operating the RV in a manner that will not overload the rack, such as by excessive speed over rough roads or speed bumps, rapid turning movements, driving the RV over changes in gradient that will bring the rack in contact with the ground, or other similar actions.

PIVOT™ v3 HITCH CAPACITY

BIKE

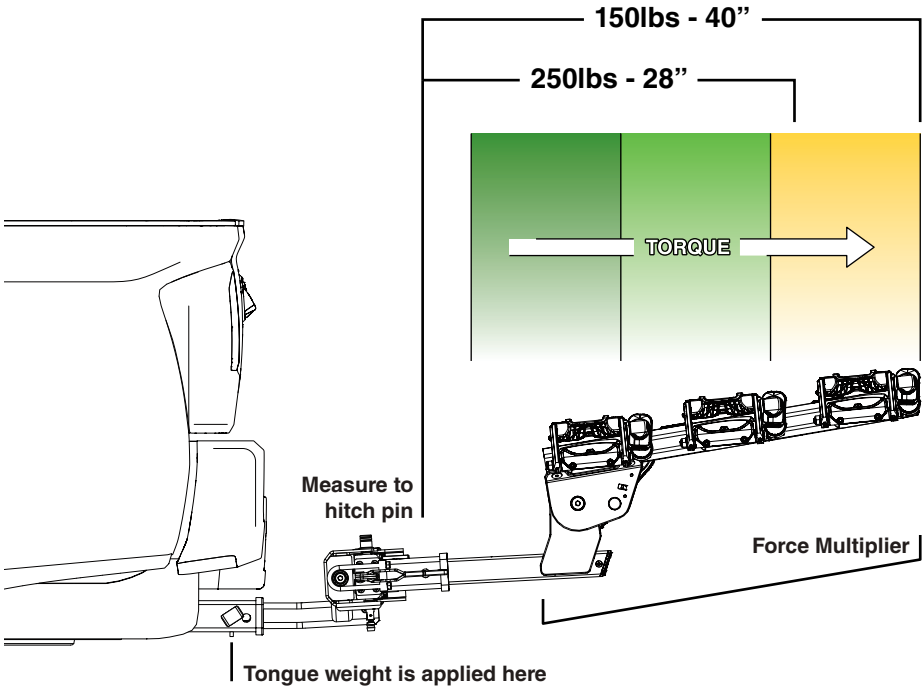

HITCH CLASS	TONGUE WEIGHT CAP.	PIVOT v3 + RACK			
		1 BIKE	2 BIKE	3 BIKE	4 BIKE
CLASS I	200 lbs	✗	✗	✗	✗
CLASS II	350 lbs	✗	✗	✗	✗
CLASS III	800 lbs	✓	✓	✓	✗
CLASS IV	1000 lbs	✓	✓	✓	✗

*This table is a generalized use guide for the PIVOT™ v3. Refer to your vehicle user manual for tongue weight capacity

**Rack shown is representative; Appearance may vary

***Kuat racks are limited to 3 bikes (maximum 250 lbs), and all other bike racks or cargo systems should follow the distance-to-weight guidelines

PIVOT™ v3 HITCH CAPACITY

CARGO

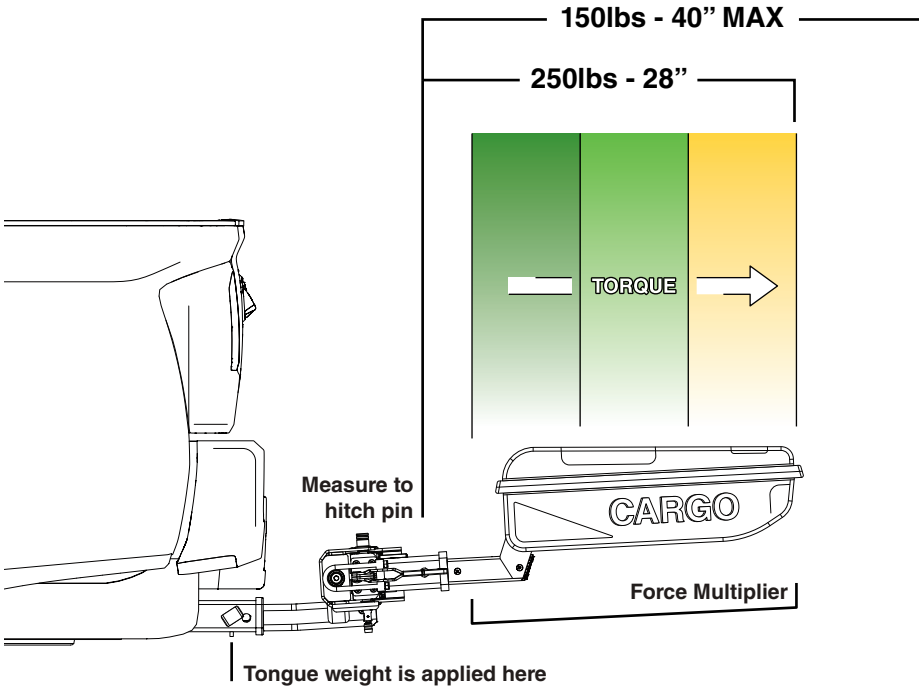

HITCH CLASS	TONGUE WEIGHT CAP.	PIVOT v3 + RACK + CARGO	
		UP TO 28" DEPTH	40" MAX DEPTH
CLASS I	200 lbs	✘	✘
CLASS II	350 lbs	✘	✘
CLASS III	800 lbs	250 lbs	150 lbs
CLASS IV	1000 lbs	250 lbs	150 lbs

*This table is a generalized use guide for the PIVOT™ v3. Refer to your vehicle user manual for tongue weight capacity

**Rack shown is representative; Appearance may vary

Parts

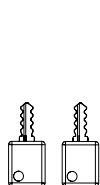

(2) Key



(1) Hitch Pin



(1) Hitch Lock

Tools

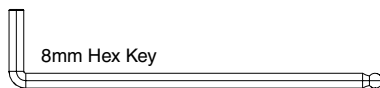

8mm Hex Key

1 We recommend that you grab a friend to help keep the rack level when tightening it into the hitch.

2 Keep your rack clean! Just like your shifter and derailleur, dirt, dust, and grime can work themselves into the mechanism resulting in sub-par performance. Periodically hose and wipe down your PIVOT v3™ to keep your rack looking good and functioning smoothly.

3 Estimated assembly time: None!

4 Don't forget to **register** your rack!

Hitch Installation

- 1 Install PIVOT™ v3 into hitch receiver on your vehicle.

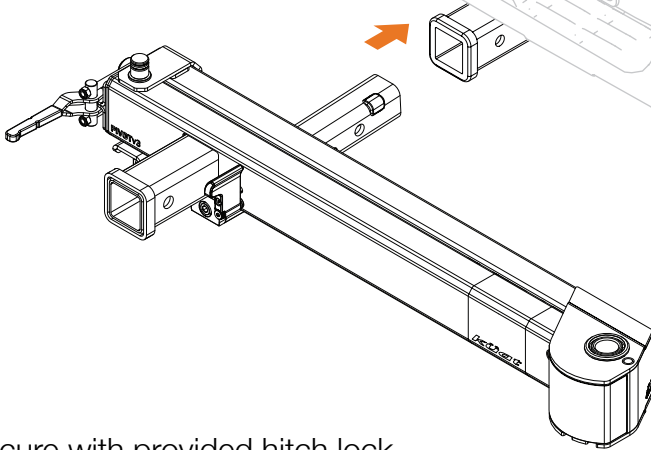

- 2 Secure with provided hitch lock.

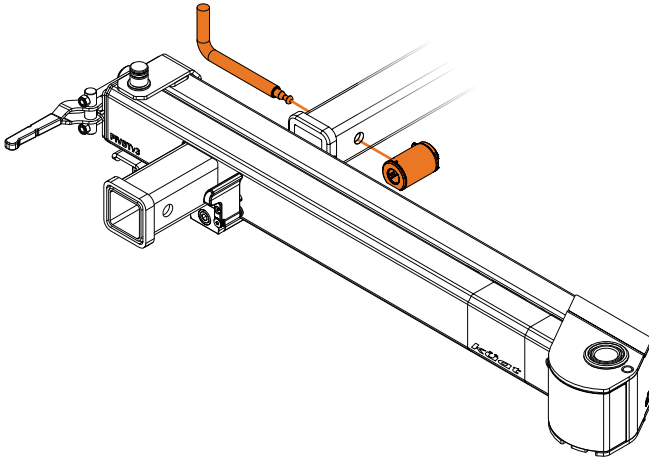

- 3 Fully tighten the FlatLock™ Cam System using the provided 8mm Hex Key.

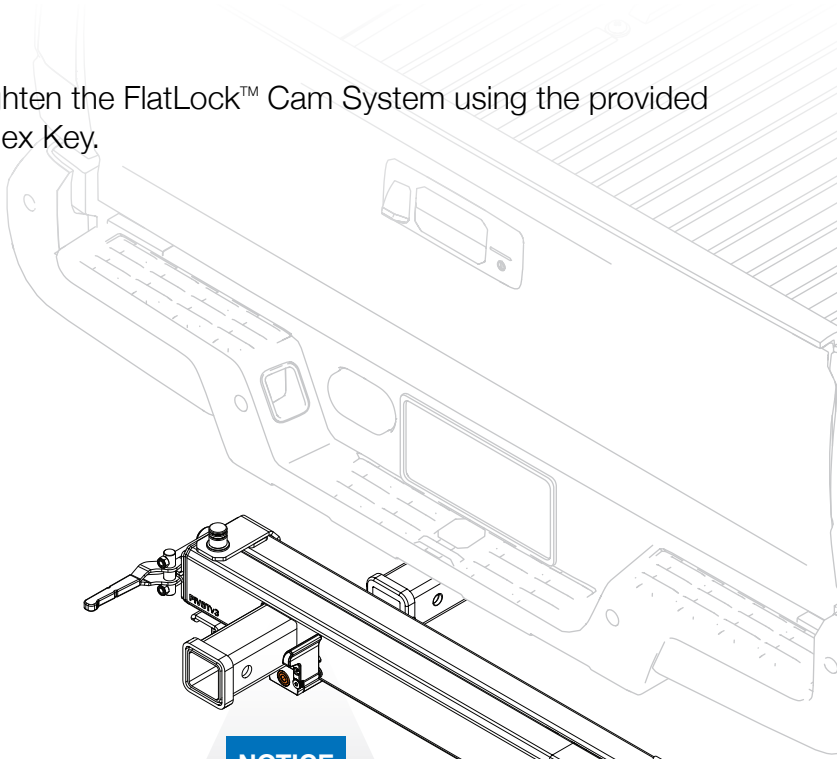

NOTICE

Lifting up slightly on the end of the Pivot v3 will help get the rack tight and level.

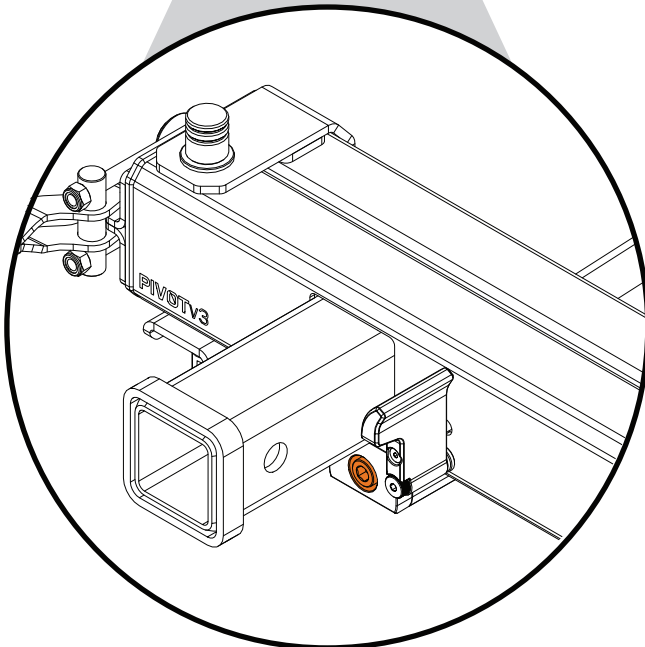

Rack/Cargo Installation

- 1 Install rack or cargo accessory according to the manufacturer's instructions.

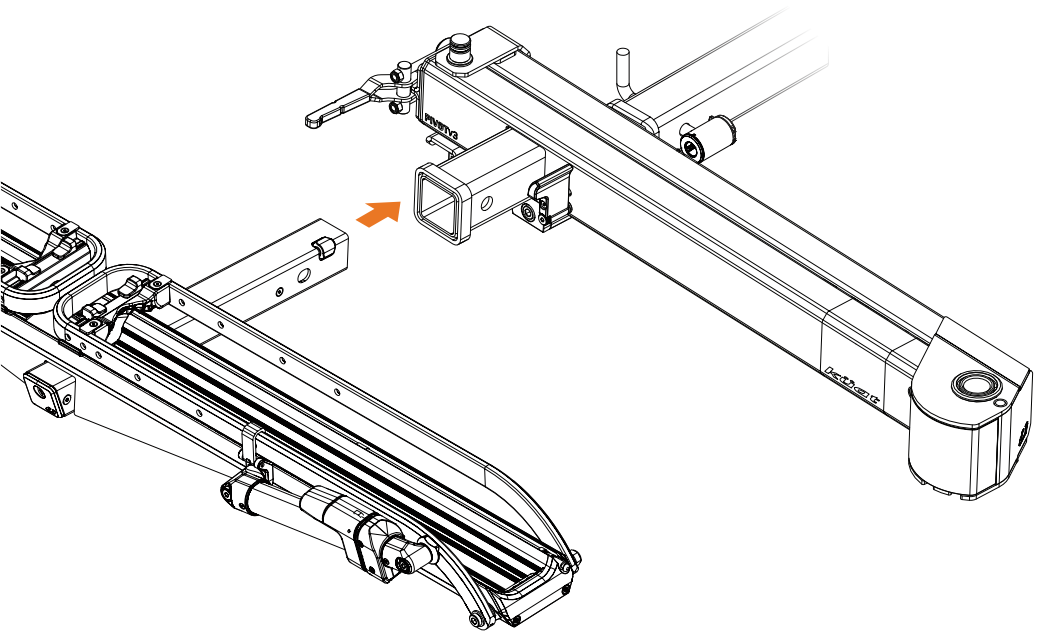

Using the PIVOT™ v3

- 1 Pull rack lever to disengage the rack.

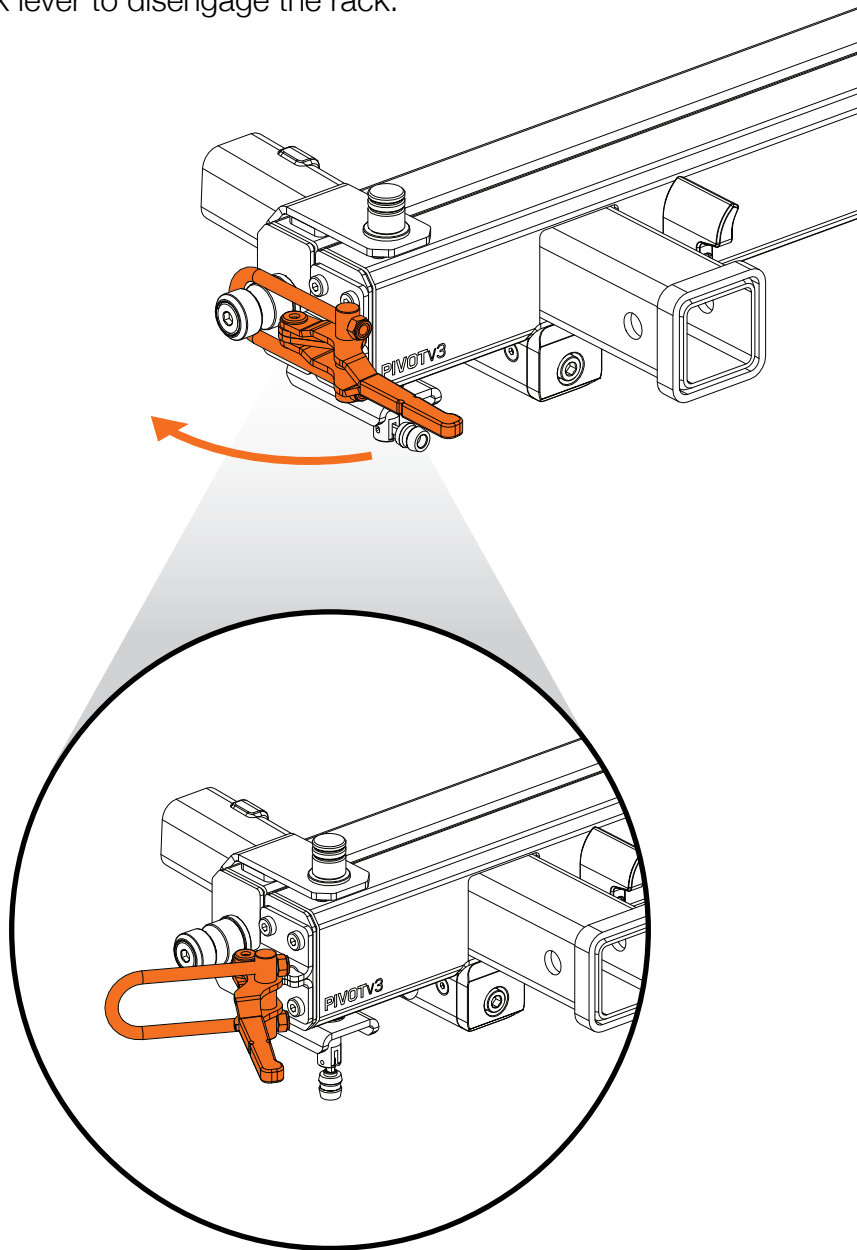

NOTICE

If you find your PIVOT v3 lever difficult to latch, or too easy to unlatch, it may be necessary to adjust the clamping force. Using a 13mm wrench, adjust the force by slightly loosening or tightening the nuts on the U-Bolt.

After adjustment, check that the lever opens and closes securely.

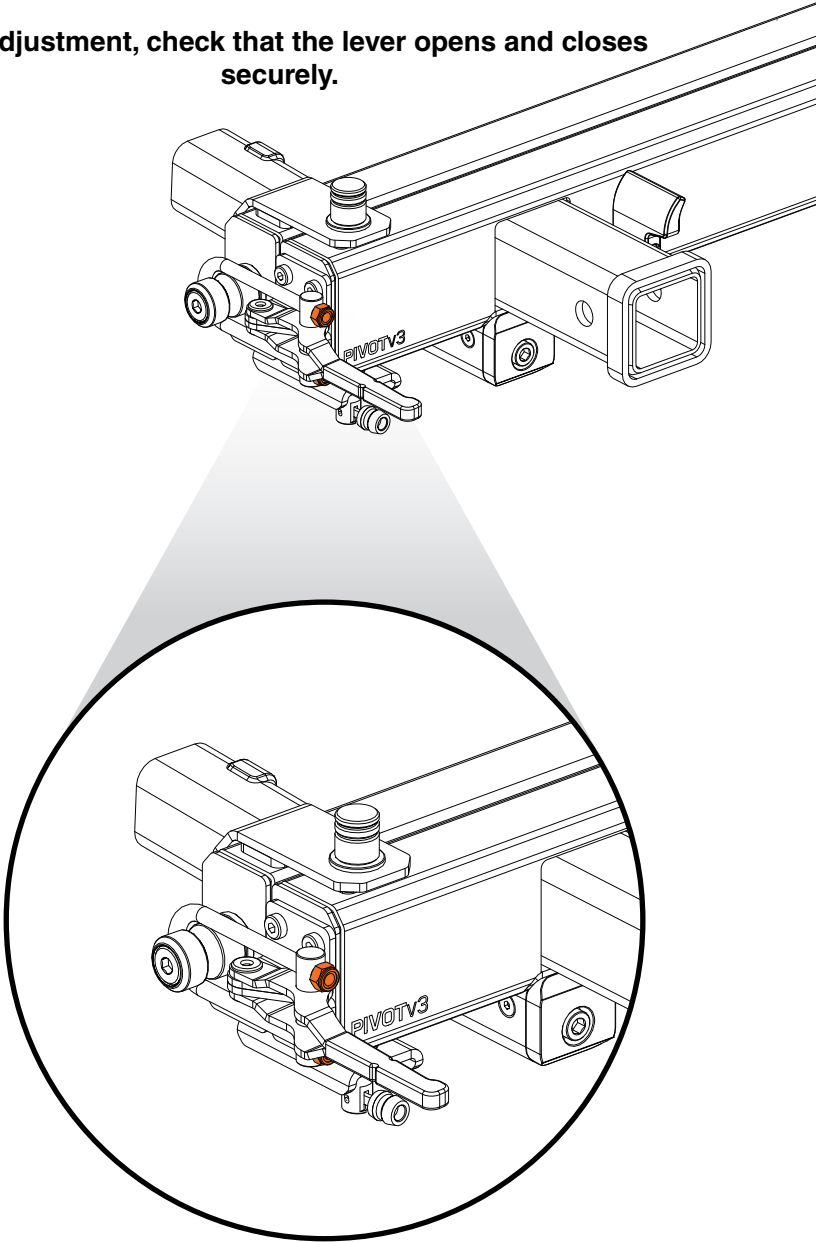

2 Align safety pin tab vertically and remove.

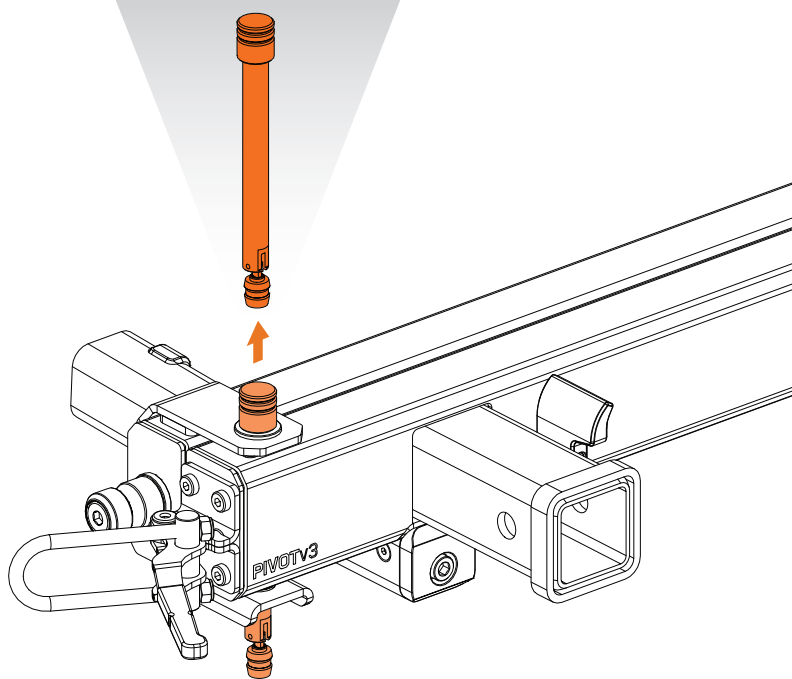
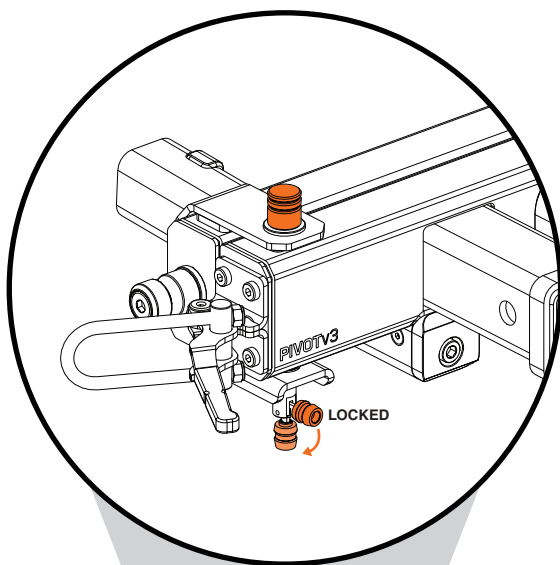

3 To release the swing-arm, pull the tab towards the hitch tube.

Pivot rack arm out to the desired angle: 90 or 120 degrees.

NOTICE

Cam Latch will “lock” into notches. You will need to pull handle to release Cam Latch each time.

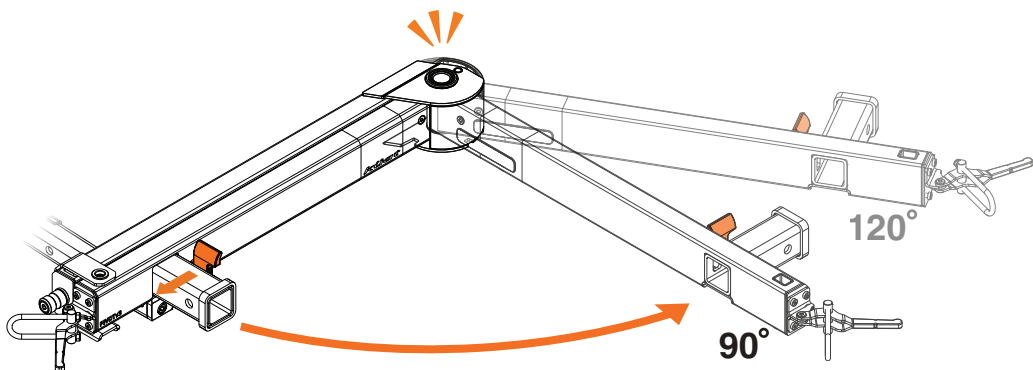

NOTICE

Use caution when opening, 120 degree position may cause interference with vehicle.

WARNING

Uncontrolled movement of the PIVOT™ arm can cause injury. Maintain (1) point of contact and avoid pinch points.

! WARNING

When closing the rack confirm that the safety pin is fully installed and the tab is rotated to the horizontal (locked) position.

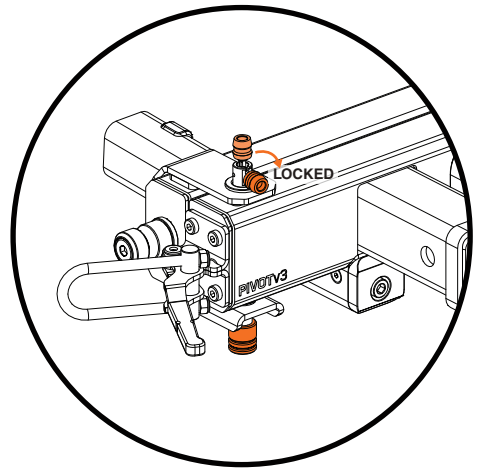
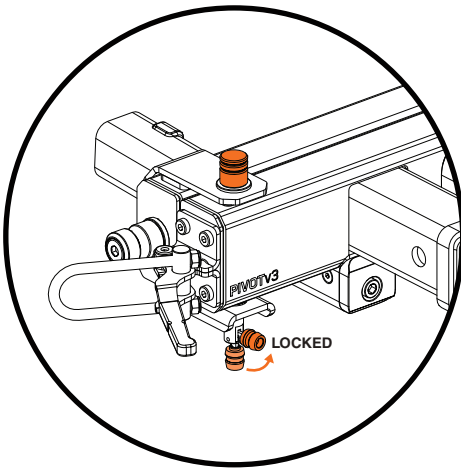

NOTICE

To avoid clearance issues on larger tires, you may also install the safety pin from the bottom of the rack. You will still need to confirm that the pin is fully installed and the tab is rotated to the horizontal (locked) position.

Q: Can I use my Pivot v3 on an RV?

A: No—The Pivot v3 is not approved for use on RVs, travel trailers, or motorhomes.

Q: Can I use the Pivot v3 with hitch extensions, such as the Kuat Hi-Lo Pro?

A: No. The Pivot v3 already functions as a hitch extension. Stacking extensions increases leverage beyond what the system is designed to handle and would void the warranty.

Q: Can I use a vertical hanging rack on my Pivot v3?

A: No—vertical hanging-style racks are not compatible with the Pivot v3. This type of setup creates excessive leverage on the system and falls outside of supported use.

If a vertical rack is a must, the Pivot XD is the better option.

Q: Can I use the Pivot v3 on a Class I Hitch?

A: The Pivot v3 is not rated for a Class I or Class II hitch. The Pivot v3 requires a Class III hitch.

Read more about our [Receiver Hitch Capacity Warning](#) and refer to our [Warranty Information](#) for receiver hitch capacity limitations.

NO WORRIES LIMITED WARRANTY

We stand behind our products, and our customer service reps are waiting to help you out if you have any problems with your product. Our limited warranty covers your purchase for life. You can review our limited warranty on our website or call customer service at the number below if you have questions or need a repair, replacement, refund, or a copy of the limited warranty.

www.kuat.com/warranty

Questions or comments?

Drop us an email or call us directly!

kuat.com | kuat.com/contact | [877.822.5828](tel:877.822.5828)

kuat[®]

1.877.822.5828
kuat.com/contact