

Classified Powershift Hub Only Process

Building requirements

- Bike Compatibility
 - o Disc brakes
 - o 142 or 148mm rear hub spacing
 - o 11-speed, 12-speed, or 13-speed groupset
 - o Di2-ready handlebars to route the shift button
- Rim compatibility (refer to partner list)
 - o Disc brakes
 - o 24 SP 142mm // 28 SP 148 mm

Powershift Kit for a Partner wheelset

Contents

- 1 Hub ETS
- 2 Disc brake Lockrings
- 1 Torque support arm
- 1 Smart Thru-axle
- 1 Cassette
- 1 Handlebar unit
- 1 Shift Button
- 1 Thru axle Spacer Kit

Availability

Please check in with your local Classified dealer to get a hold of the wheelset You can find all Classified dealers in our dealer locator [HERE](#)

Pricing

For the total cost of the Powershift Kit component for your partner wheelset click [HERE](#) for our system builders. The wheelset pricing differs per manufacturer and wheelset. Some bike shops can also add an installation charge when building classified on your bike.

Powershift Kit (inc. Hubshell) for third-party rim*

Contents

- 1 Hub ETS
- 2 Disc brake Lockrings
- 1 Torque support arm
- 1 Smart Thru-axle
- 1 Cassette
- 1 Handlebar unit
- 1 Shift Button
- 1 Thru axle Spacer Kit
- 1 Hub shell

Availability

Please check in with your local Classified dealer to get a hold of the wheelset You can find all Classified dealers in our dealer locator [HERE](#)

Pricing

For the total cost of the Powershift Kit component for your third party rim click [HERE](#) for our system builders.

Your favourite local wheel builder can quote you on labour charges.

*No spokes included

Contents, availability, and pricing and Building guidelines

- 2:1 SP spoke pattern (100mm) // 1:1 SP spoke pattern 110mm
- 24 holes (100, 142) // 28 holes (110,148)
- Centerlock (outside thread)
- We recommend using the DT-Swiss Spoke calculator found [HERE](#)
- Please check with your Rim manufacturer if nipple washers and thread lock are necessary or recommended
- Max. spoke tension for the hub shell is 120kg
- Please check spoke tension with the rim manufacturer

Hub Data to use in the spoke calculator

Front hub drawing 100mm .

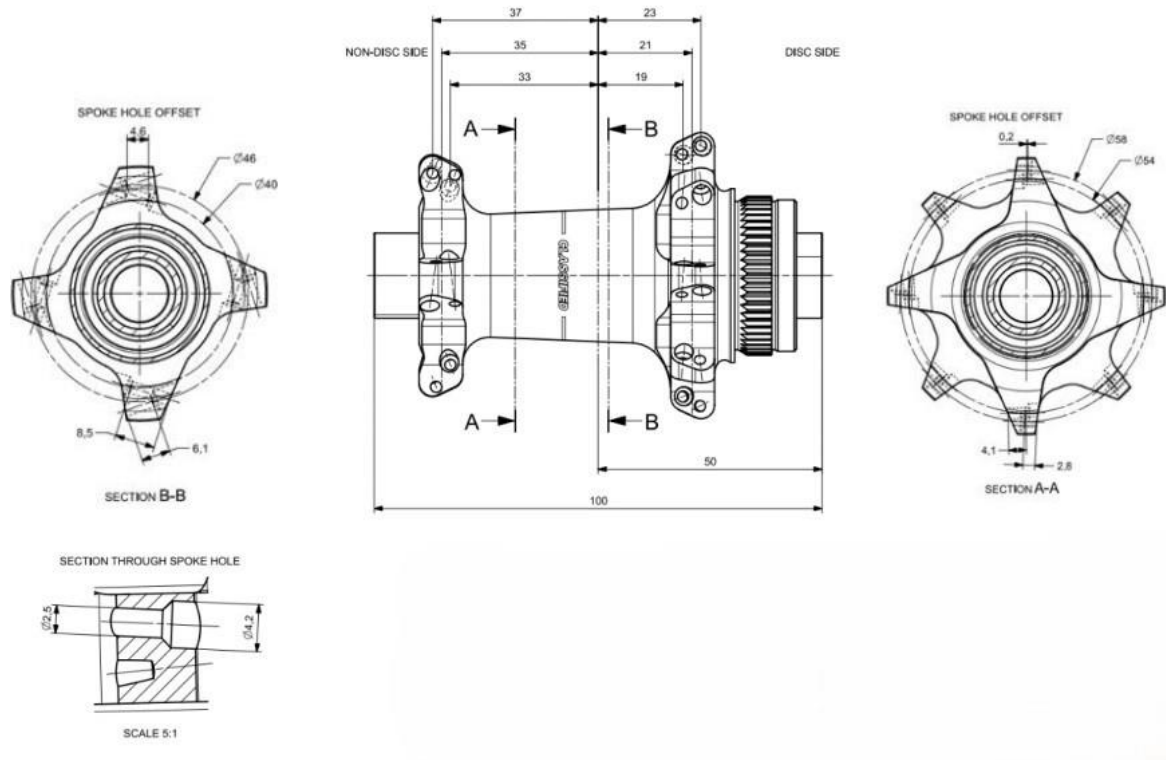

2. HUB

TYPE

User defined straightpull

MODEL ⓘ

User defined straightpull

PITCH CIRCLE LEFT ⓘ

56 mm

PITCH CIRCLE RIGHT ⓘ

43 mm

FLANGE DISTANCE LEFT ⓘ

21 mm

FLANGE DISTANCE RIGHT ⓘ

35 mm

OFFSET SPOKE HOLE LEFT ⓘ

.01 mm

OFFSET SPOKE HOLE RIGHT ⓘ

2.3 mm

∅-SPOKE HOLE ⓘ

2.5 mm

WEIGHT

110 g

Rear Hub Drawing 142mm

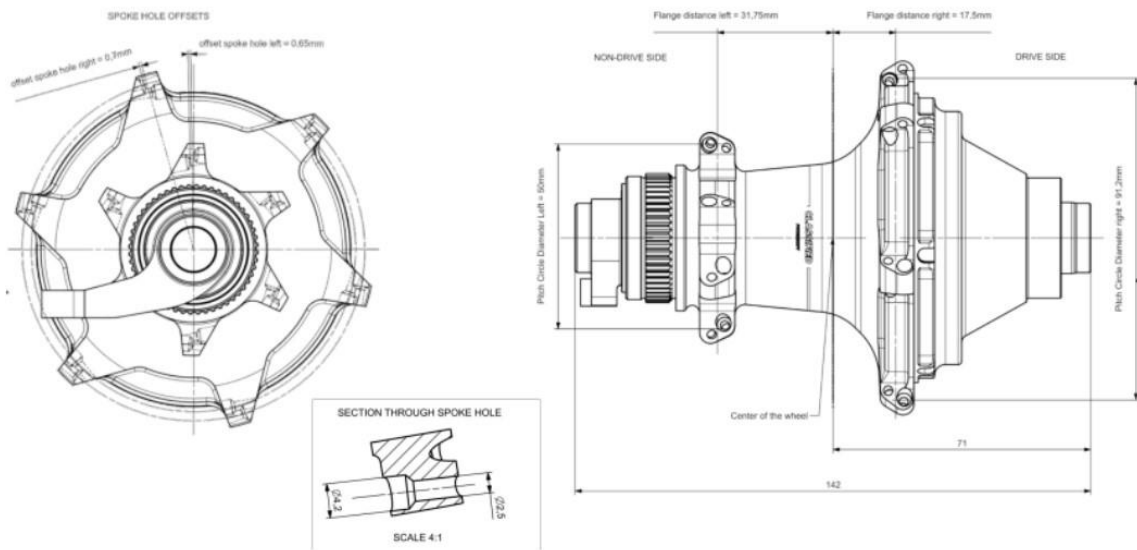

2. HUB

TYPE

User defined straightpull

MODEL ⓘ

User defined straightpull

PITCH CIRCLE LEFT ⓘ

50 mm

PITCH CIRCLE RIGHT ⓘ

91.2 mm

FLANGE DISTANCE LEFT ⓘ

31.75 mm

FLANGE DISTANCE RIGHT ⓘ

17.5 mm

OFFSET SPOKE HOLE LEFT ⓘ

.65 mm

OFFSET SPOKE HOLE RIGHT ⓘ

.7 mm

Ø-SPOKE HOLE ⓘ

2.5 mm

WEIGHT

450 g

Front Hub Drawing 110mm (Boost)

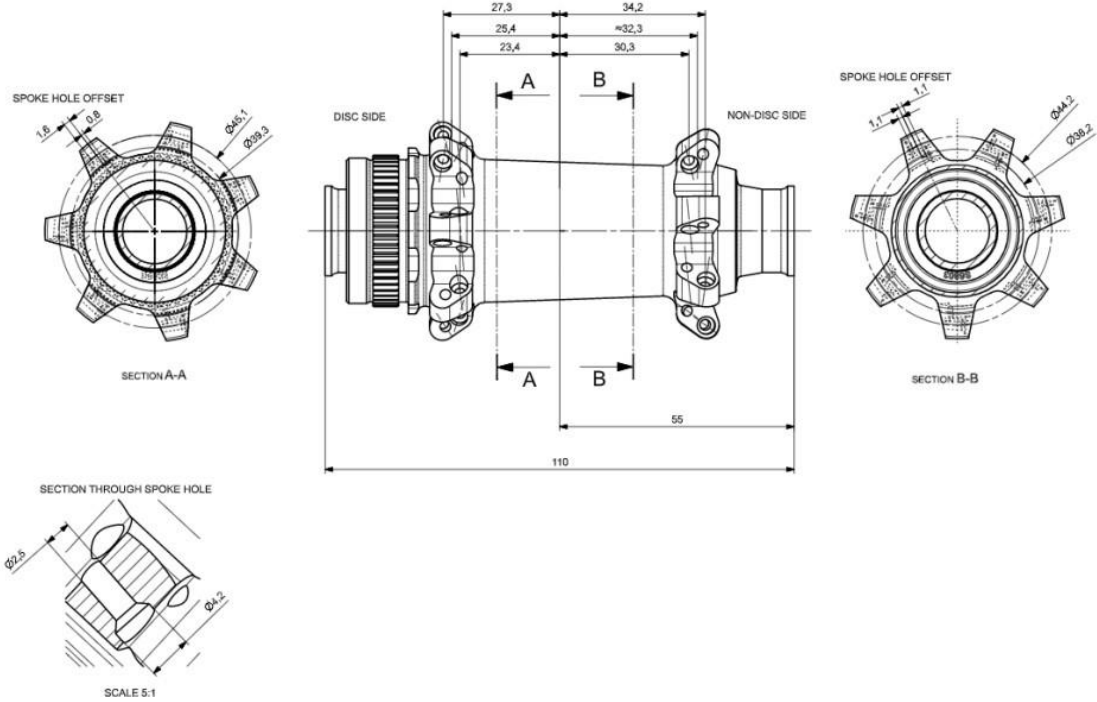

2. HUB

TYPE
 ✓

MODEL ⓘ
 ✓

PITCH CIRCLE LEFT ⓘ <input type="text" value="44.6"/> mm	PITCH CIRCLE RIGHT ⓘ <input type="text" value="38.7"/> mm
FLANGE DISTANCE LEFT ⓘ <input type="text" value="25.44"/> mm	FLANGE DISTANCE RIGHT ⓘ <input type="text" value="32.3"/> mm
OFFSET SPOKE HOLE LEFT ⓘ <input type="text" value=".8"/> mm	OFFSET SPOKE HOLE RIGHT ⓘ <input type="text" value="1.1"/> mm
Ø-SPOKE HOLE ⓘ <input type="text" value="2.5"/> mm	WEIGHT <input type="text" value="100"/> g

Rear Hub Drawing 148mm (Boost)

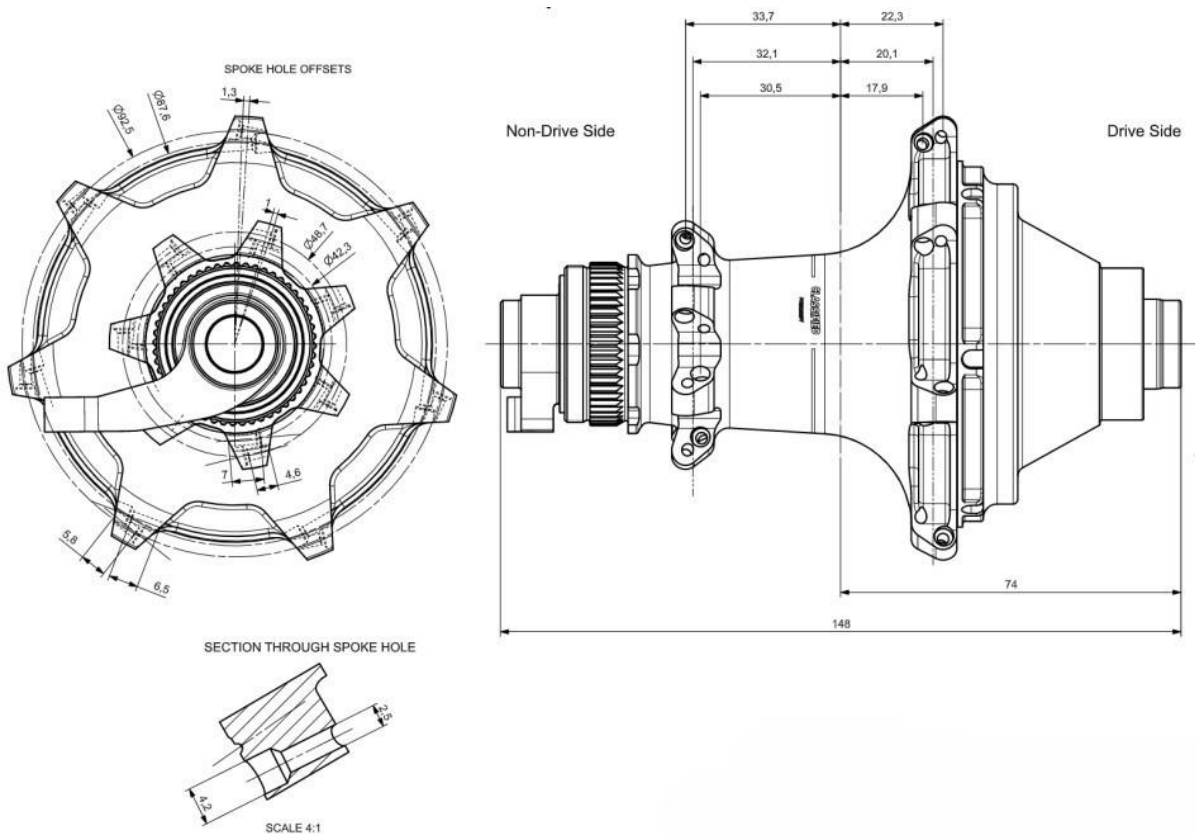

2. HUB

TYPE: ✓

MODEL ⓘ: ✓

PITCH CIRCLE LEFT ⓘ: <input type="text" value="45.6"/> mm	PITCH CIRCLE RIGHT ⓘ: <input type="text" value="90.05"/> mm
FLANGE DISTANCE LEFT ⓘ: <input type="text" value="32.1"/> mm	FLANGE DISTANCE RIGHT ⓘ: <input type="text" value="20.1"/> mm
OFFSET SPOKE HOLE LEFT ⓘ: <input type="text" value="1"/> mm	OFFSET SPOKE HOLE RIGHT ⓘ: <input type="text" value="1.3"/> mm
Ø-SPOKE HOLE ⓘ: <input type="text" value="2.5"/> mm	WEIGHT: <input type="text" value="450"/> g

Drilling Angles Confirmation

Data Necessary:

- ERD (Effective Rim Diameter) supplied by the Rim Manufacturer
- Drilling Angles from Rim Manufacturer
- Drilling Angle Tool from Classified

Procedure:

- Consult the value for the ERD in the Drilling Angle Tool from Classified accordingly to ROAD/MTB and FRONT/REAR
- If the ERD value doesn't exist in the table, insert you ERD the Grey box (Example down ERD:537)
- Drill Rim accordingly the Spoke Pattern and the Drilling Angles

CLASSIFIED

The ERD (Effective Rim Diameter) can be set manually. The table below illustrates typical values for most used rim heights.

Symmetric Rim		Allowed tolerance on drilling angles is ± 0.5 degrees			
Rim Height [mm]	Effective Rim Diameter [mm]	ERD DS Angle 1 [Degrees]	NDS Angle 2 [Degrees]	Angle 3 [Degrees]	Angle 4 [Degrees]
20	600	7.3	4.3	5.4	4.1
30	580	7.6	4.5	5.5	4.3
40	560	7.9	4.6	5.7	4.4
50	540	8.2	4.8	6.0	4.6
60	520	8.6	5.0	6.2	4.7
65	510	8.8	5.1	6.3	4.8
USER INPUT	537	8.3	4.9	6.0	4.6

Asymmetric Rim		Allowed tolerance on drilling angles is ± 0.5 degrees			
Rim Height [mm]	Effective Rim Diameter [mm]	DS Angle 1 [Degrees]	NDS Angle 2 [Degrees]	Angle 3 [Degrees]	Angle 4 [Degrees]
20	600	7.6	4.0	5.4	4.1
30	583	7.9	4.1	5.5	4.2
40	562	8.2	4.3	5.7	4.4
50	539	8.6	4.5	6.0	4.6
USER INPUT					

*Please use the boxes marked in [GREY] for custom entry.

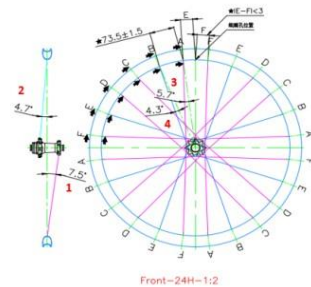

Assembly Guidelines:

- Rim Holes: 24 Holes(142); 28 Holes(148)
- The hubshell should be assembled using a Dummy Hub supplied by Classified Cycling or a Powershift Hub with the Torque support mounted
- Only Assemble Straight-Pull Spokes (Round or Flat)
- Spoke Diameter accepted: 14G(2,0mm) and 14G with Reinforced head (Example: Pillar 14G with PSR)
- Max Flat Spoke Width: 2,5mm
- Align the Classified Powershift logo with the valve hole, from the NDS (Disc Side) viewpoint, 1 st Spoke to be assembled, should be on the left side of the valve hole
- Spokes should be assembled with 3 Cross NDS and 1 Cross DS (100 Hub); 2Crosses; (142 Hub) 3 Crosses (148 Hub)
- Both cold and hot lacing are acceptable
- From the NDS (Disc Side) viewpoint, the spokes in the valve hole should be parallel
- Max. spoke tension for the hub shell is 120kg Classified Third party wheel building guide

Classified cycling is a company that strives to be available to all, this means we do encourage you to build our Powershift hub into your favourite rims. To get the Powershift Hub kit With Hubshell, we have a handy system builder found [HERE](#). That, with a compatible rim of choice and your favourite local Wheel builder can build your new dream wheels.

NOTE: *By not selecting a Classified ready rim you will be voiding the warranty on every build with the Classified hubshell. See our partners list [HERE](#).*

⚠Disclaimer⚠

This document provides necessary information about how to build a wheel with the Classified Powershift Hub, please read the whole document before attempting to build your wheel.

All remarks and instructions in this document have to be followed for user safety and Classified is never liable for imperfections and breaks in the Rim.

Classified will only warranty the hub if used correctly and the wheel and bike will comply with all requirements listed below.

This disclaimer is valid for everyone attempting to build a wheel with the Classified Powershift Hub, professional wheel builders, bike shops, and end consumers alike.