

CLASS 4TM v2

USER GUIDE

Included

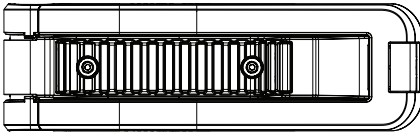

(2) Class 4^m v2 Racks

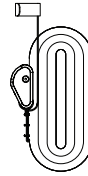

(2) Boat Ties

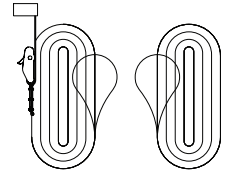

(2) Bow/Stern Sets



Lock Keys



Cool Keychain

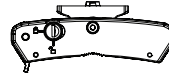

(2) Flip Mounts
Locking

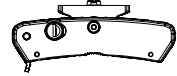

(2) Flip Mounts
Non-Locking



M4 Hex Key



(4) M6x30mm Bolt



(4) M6 Lock Washer

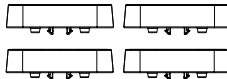

(4) Flush Mounts



(4) T-Channel Bolt Heads

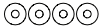

(4) M6 Washer

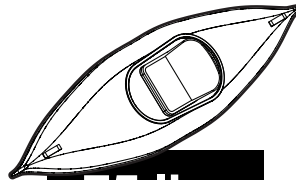

75 lbs

Maximum Boat Weight

4.25"

Max Crossbar Width



2" | .5"

Max / Min Crossbar Height

Class 4^m v2 will work with round, square & aero bars within this size range.

Installing Universal Flip™ Mounts

- 1 Open your Class 4™ v2 rack by pulling the butterfly lever and lifting the clamshell open.

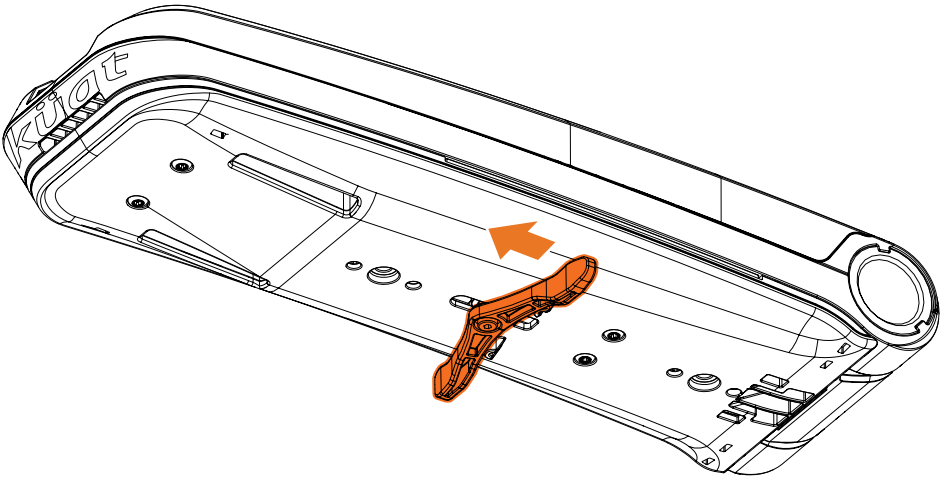

- 2 Once the Class 4™ v2 rack is opened, ensure alignment of the following components: one (1) locking Flip mount, one (1) non-locking Flip mount, two (2) M6 bolts, two (2) M6 lock washers, and two (2) M6 washers.

! If using flush mount kit skip to installing flush mounts.

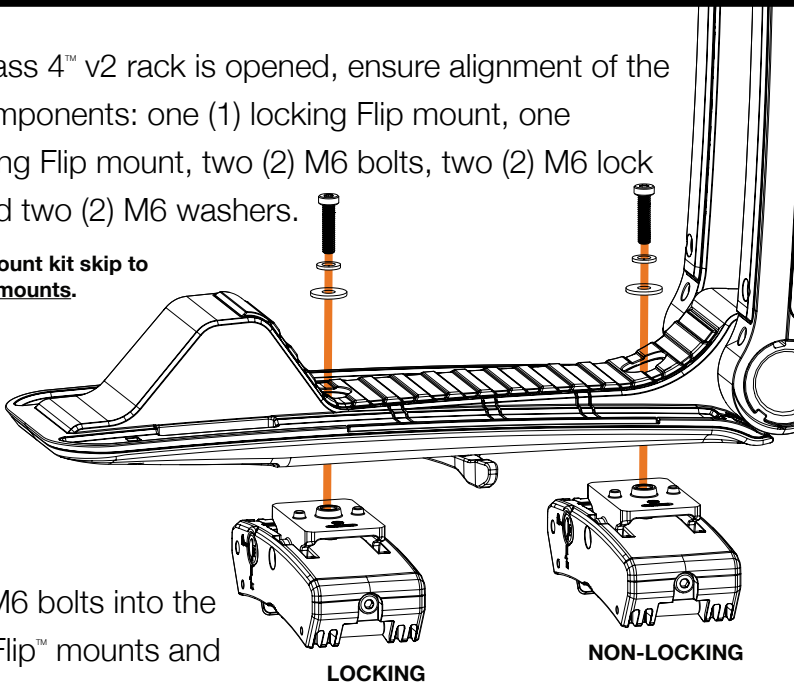

- 3 Thread the M6 bolts into the designated Flip™ mounts and tighten them using the provided M4 hex key.

! Repeat for the second Class 4™ v2 rack.

Leveling

Depending on your vehicle and crossbars, it may be necessary to adjust the angle of your racks so they sit level.

- 4 Adjust the angle of your mounts and rack using the angle adjustment bolt and the provided M4 hex key.

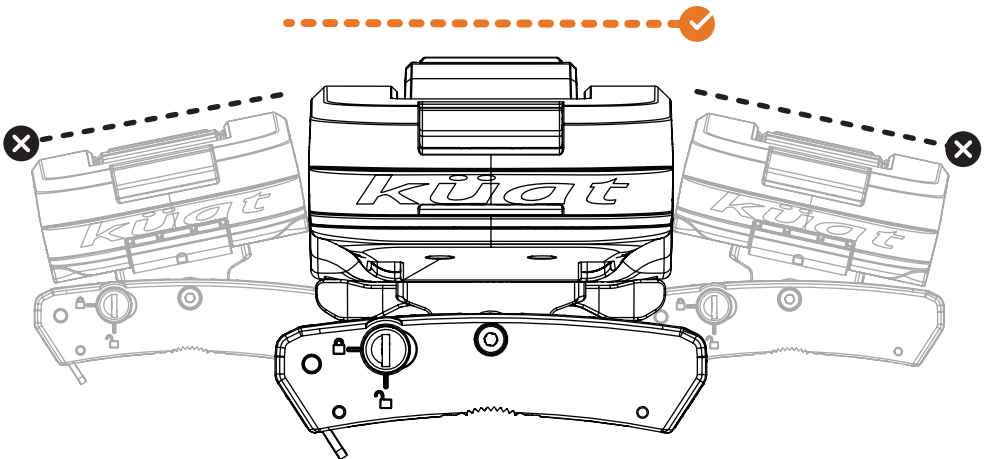
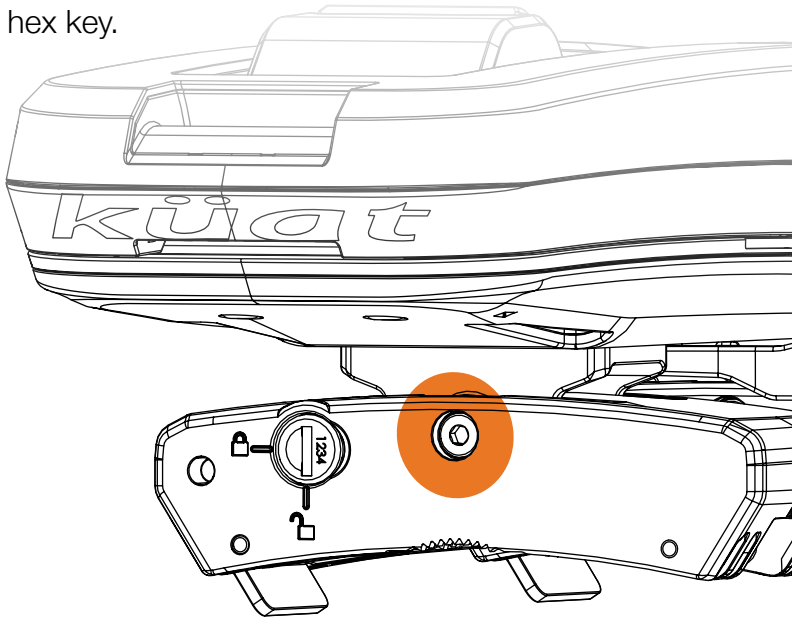

- 5 Following the adjustments, confirm that your rack is relatively level to the ground, and securely fasten the angle adjustment bolt.

Using the Universal Flip™ Mounts

- 1 Pivot the lever upward to release strap.

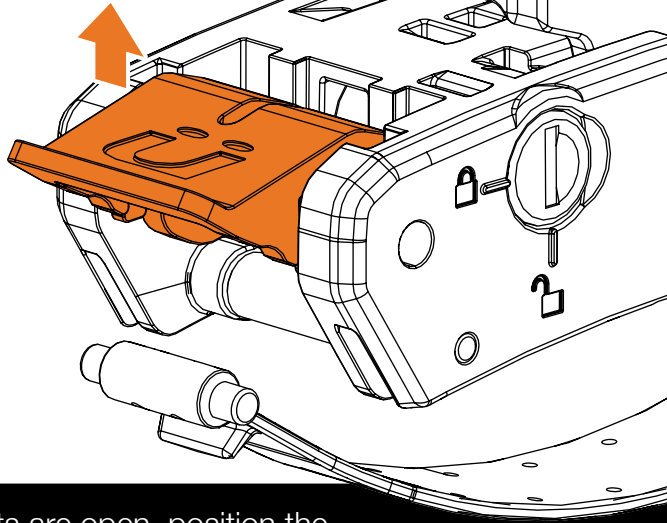

- 2 Once both Flip mounts are open, position the Class 4™ v2 onto the crossbar, threading the straps underneath and securing them into the strap lever.

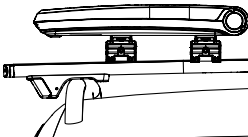

Use Strap Option 1

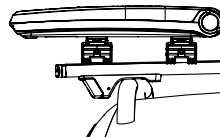

Use Strap Option 2

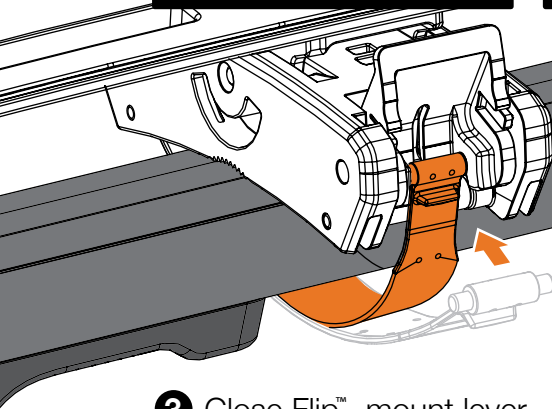

- 3 Close Flip™ mount lever and repeat for opposite side.

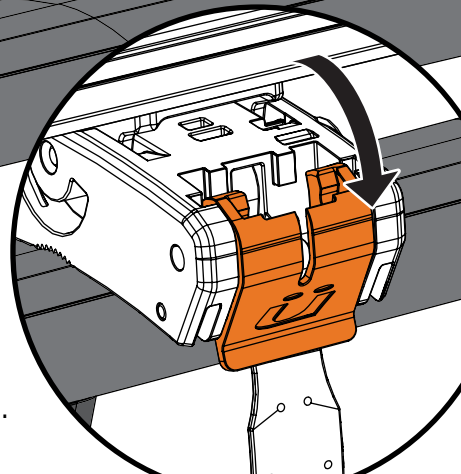

- 4 Ensure a snug fit of the mounts onto the crossbar by re-tightening the strap tensioner using the provided M4 hex key.

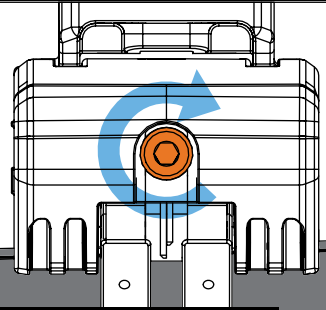

! Overtightening can damage crossbar and mount

! When tightening Flip™ straps, check the lever periodically. Lever should be snug, but not too difficult to articulate. Once straps have been properly adjusted to the crossbar, further adjustment should not be necessary to remove or reinstall the racks.

- 5 Repeat steps 1-4 for the second Class 4™ v2, ensuring both racks are properly aligned and leveled with the vehicle.

! **Always check that racks are secure prior to travel.**

Securing Flip™ Mounts

- 6 After each Class 4™ v2 has been installed to the crossbar, secure the Flip™ mounts using the provided key and integrated lock on the side of each locking mount.

! Küat recommends articulating dummy locks to the “locked” position on each non-locking Flip™ mount.

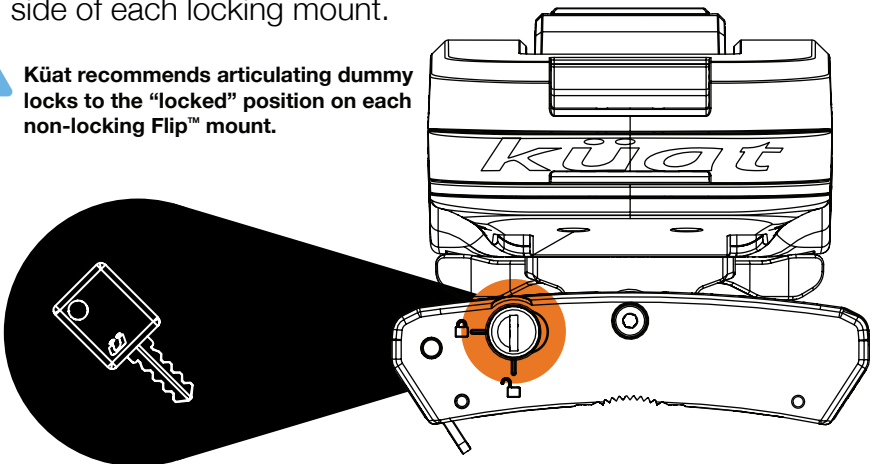

Installing Flush Mounts

- 1 With the Class 4™ v2 in the open position, align (2) Flush Mounts, (2) M6 bolts and (2) t-channel bolt heads beneath each mounting bolt hole.

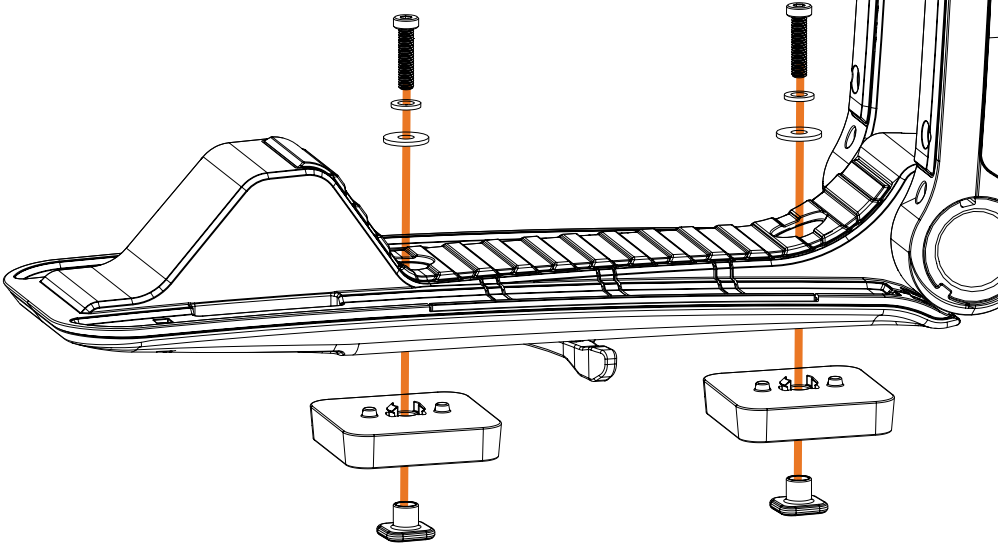

- 2 Guide the M6 bolt through the Flush Mount into the t-channel bolt head and secure it by threading it using the M4 hex key.

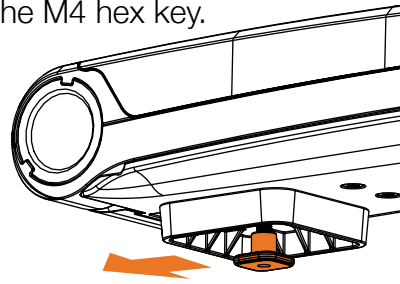

Crossbar Mounting

- 3 Slide the rack with installed t-channel bolt heads into the corresponding t-channel on the crossbar, and securely fasten by tightening with the M4 hex key.

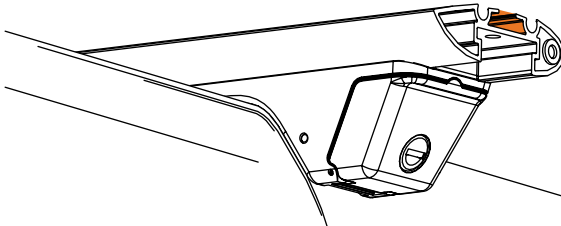

Feeding Straps and Loading Boat

- 1 Thread the straps through the straps port in each Class 4™ v2 lid. Pull the straps through and place them on each side for convenient access later.

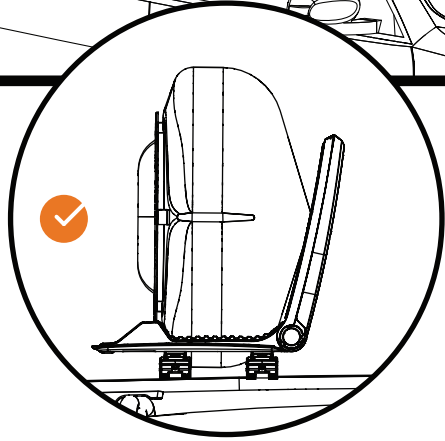
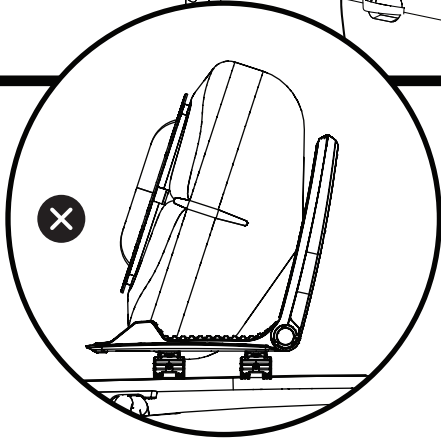
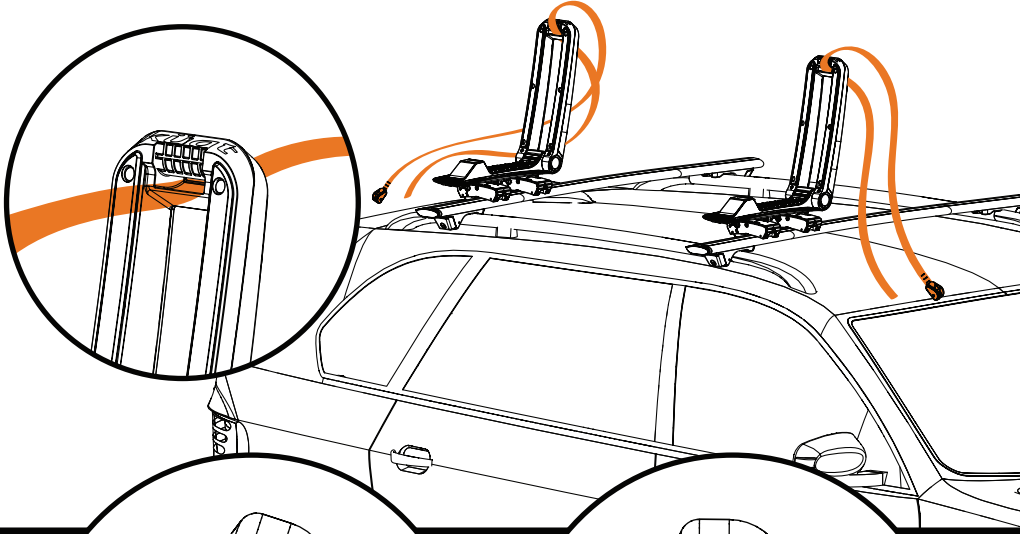

- 2 Load the boat with the hull positioned vertically.

Bring the straps up and over the bow and stern of the boat.

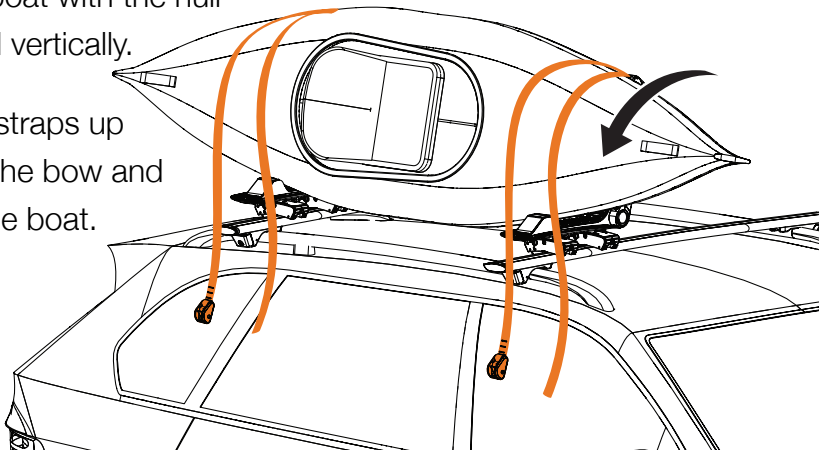

- 3** Guide the strap end through the lower strap port, around the crossbar, up through the opposite strap port, and secure it into the cam buckle.

Strap Option 1

Use with Class 4™ v2 mounted behind roof bar.

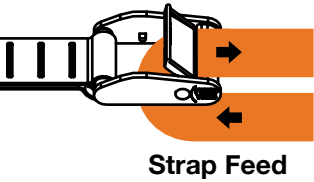

Strap Feed

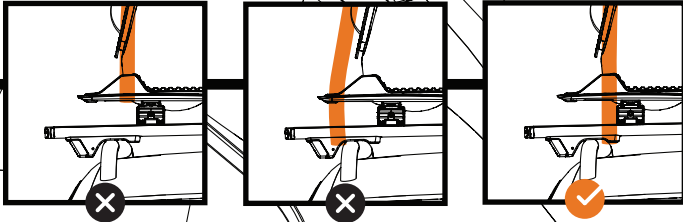

Strap Option 2

Use with Class 4™ v2 mounted in front of roof bar.

- 4** Direct the strap end around the crossbar and insert it into the cam buckle. Ensure a secure fit, and manage any excess strap by using the provided Velcro to secure it to the strap.

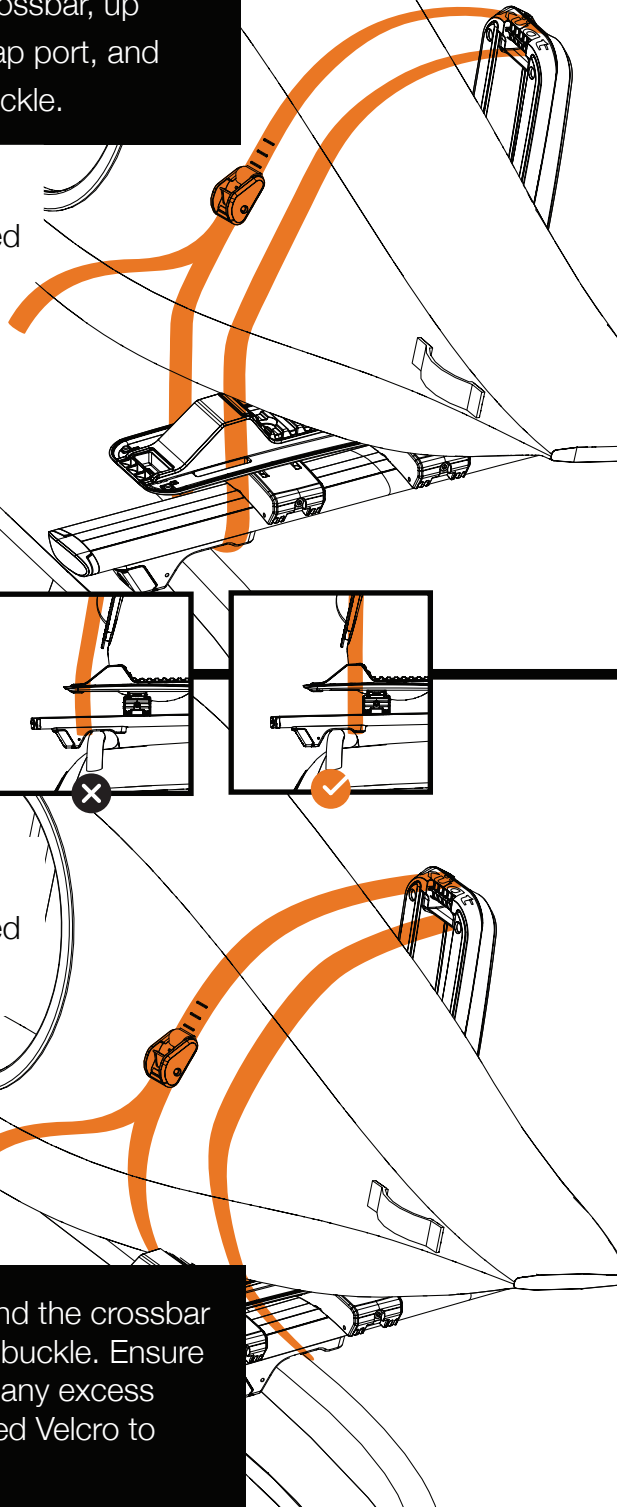

Fixing Bow and Stern Lines

- 5 Thread the cam of the short looped strap through the bow handle and loop it back through

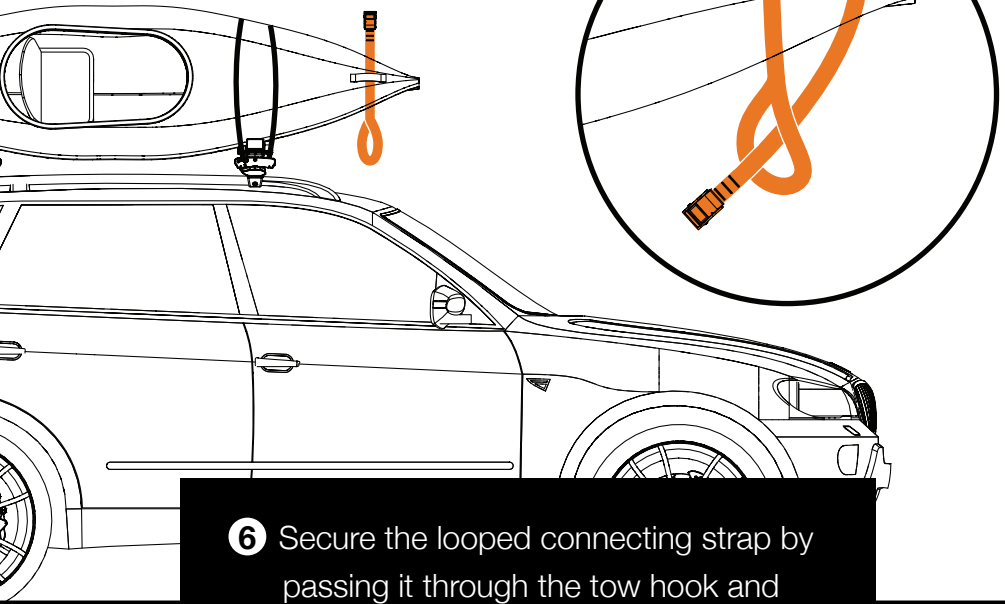

- 6 Secure the looped connecting strap by passing it through the tow hook and looping it back through.

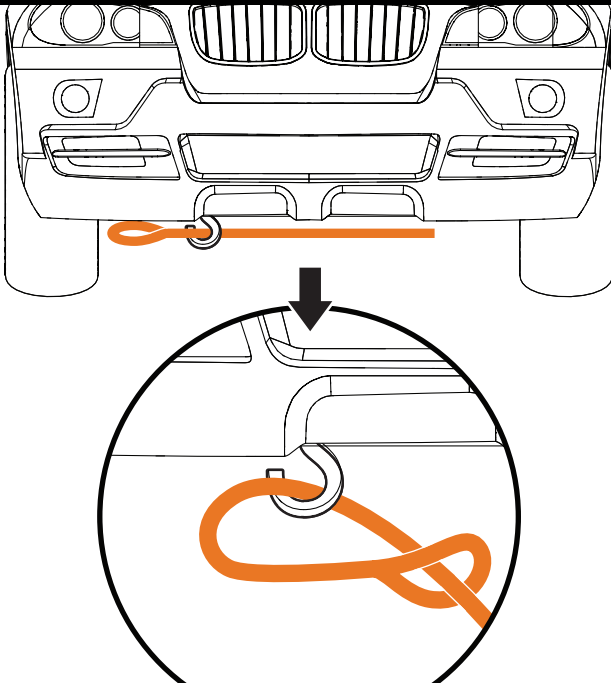

- 7** Feed tow hook strap into cam strap affixed to bow handle to secure bow line.

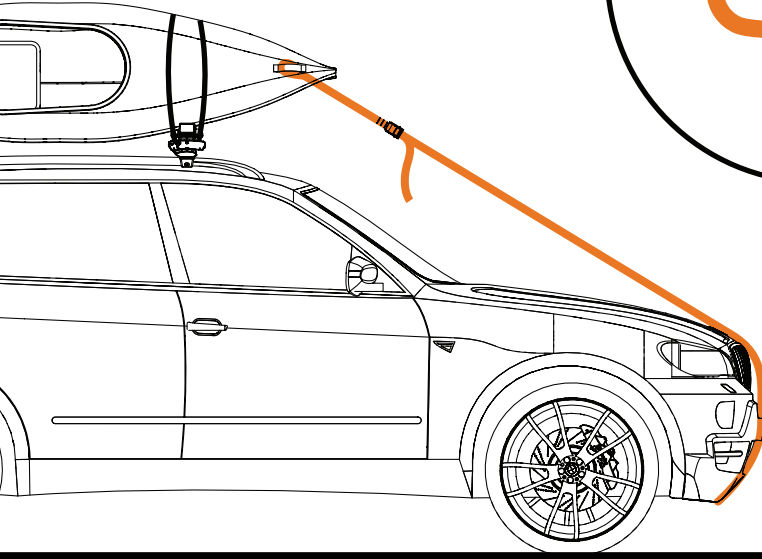
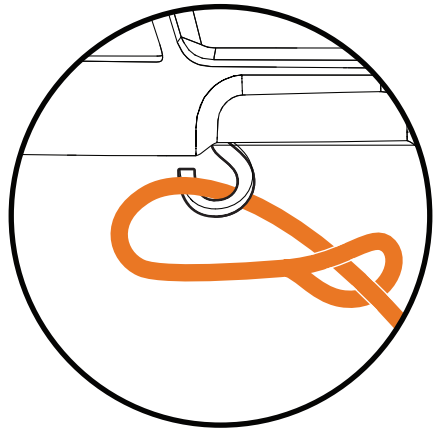

- 8** Repeat step 7 for the stern line.

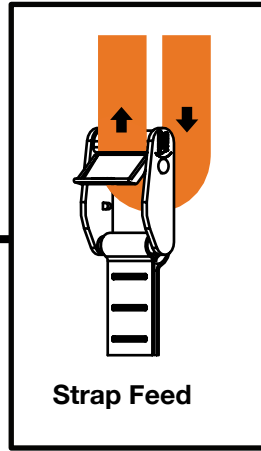

Strap Feed

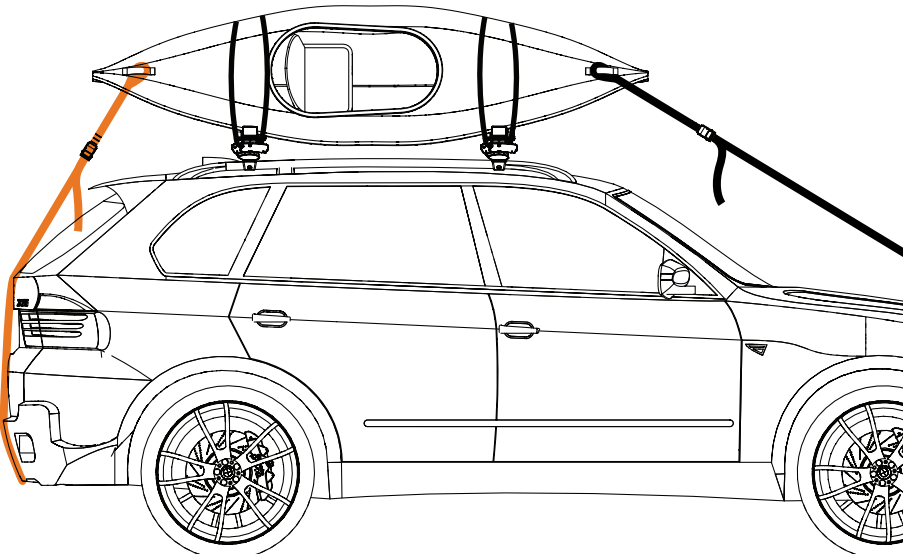

- 9 The tow hook straps are equipped with a protective sleeve designed to shield against contact between the strap and your vehicle. In cases of multiple contact points, the protective sleeve can be modified by cutting and re-sleeving to extend protection to additional areas.

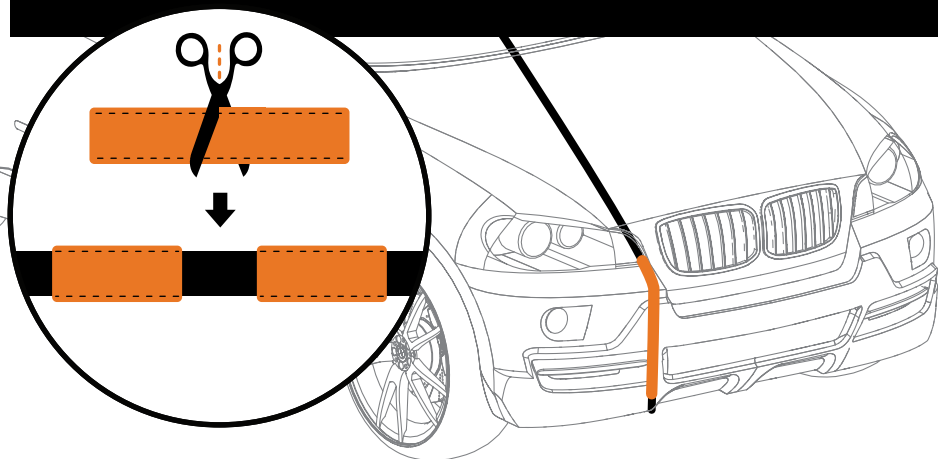

Closing the Class 4™ v2

- 10 When not in use, the Class 4™ v2 kayak rack can be folded down. Pull the butterfly lever forward from either side and lower the rack lid to stow it away.

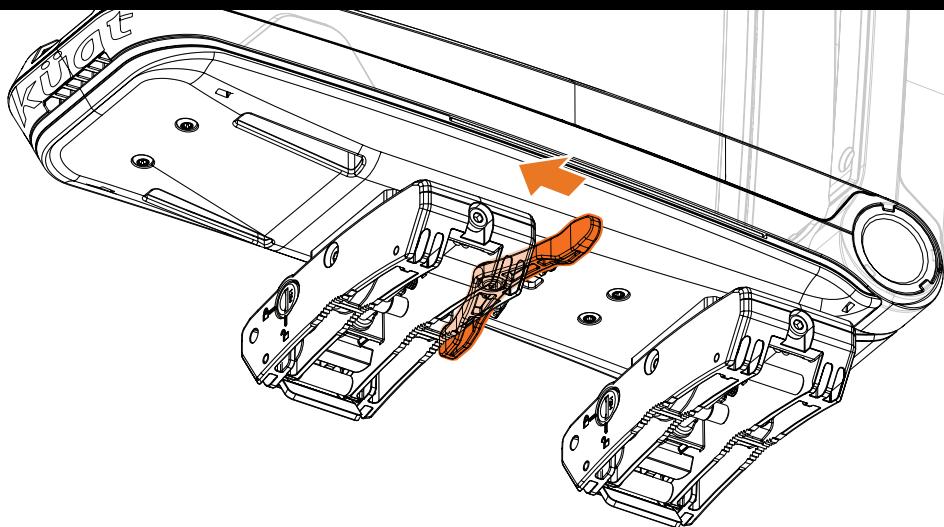

Warnings

CLASS 4™ v2

Max Boat Weight

75 lb
34 kg

WARNINGS

- Follow instructions for proper assembly, installation and use.
- Do not exceed your vehicle's crossbar load limits.
- Always use the bow and stern straps.
- Check your straps and hardware prior to each trip and periodically during long trips.
- Use caution when lifting your rear hatch while the boat is mounted.
- Lubricate lock cores at the start of each season using graphite or dry lube.
- Do not use tarps, rain covers or wind covers with this product.
- Do not take through automatic car wash.
- Drive responsibly.

If you have questions or problems, please contact Kūat Racks directly by calling toll free 1(877)822-KUAT, or by email: info@kuat.com

ADVERTENCIAS

- Siga las instrucciones para un montaje, instalación y uso adecuados.
- No exceda los límites de carga de sus vehículos.
- Utilice siempre las correas de proa y popa.
- Revise sus correas y equipos de ajuste antes de cada viaje y periódicamente durante viajes largos.
- Tenga cuidado al levantar su escotilla trasera mientras el barco está montado.
- Lubrique los núcleos del candado al comienzo de cada temporada usando grafito o lubricante seco.
- No utilice lonas, cubiertas de lluvia o cubiertas de viento con este producto.
- No llevar a través del lavado automático de automóviles.
- Conduzca con responsabilidad.

AVERTISSEMENTS

- Suivez les instructions pour un assemblage, une installation et une utilisation appropriés.
- Ne dépassez pas les limites de charge de votre véhicule sur la barre transversale.
- Utilisez toujours les sangles d'arc et poupe.
- Vérifiez vos sangles et votre matériel avant chaque voyage et périodiquement lors de longs voyages.
- Faites preuve de prudence lorsque vous soulevez le hayon arrière lorsque le bateau est monté.
- Lubrifiez les noyaux de blocage au début de chaque saison à l'aide de graphite ou de lubrifiant sec.
- N'utilisez pas de bâches, de couvertures anti-pluie ou anti-vent avec ce produit.
- Ne pas utiliser de lave-auto automatique.
- Conduire de manière responsable.

NO WORRIES LIMITED WARRANTY

We stand behind our products, and our customer service reps are waiting to help you out if you have any problems with your product. Our limited warranty covers your purchase for life. You can review our limited warranty on our website or call customer service at the number below if you have questions or need a repair, replacement, refund, or a copy of the limited warranty.

www.kuat.com/warranty

Questions or comments?

Drop us an email or call us directly!

kuat.com | info@kuat.com | [877.822.5828](tel:877.822.5828)

Notes:

kuat

1.877.822.5828

info@kuat.com

kuat.com